

Remote Pressure Monitoring - Quick Start Guide

Valve Box Installation Instructions

HYDRO-GUARD™

- 1**  **Verify Cell Coverage at Installation Site.**
Place cell phone of same carrier (Verizon or AT&T) at the planned installation location, and verify the signal quality. Indicator must have a minimum of two (2) bars.

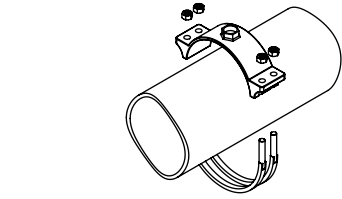

- 2** Install service saddle.

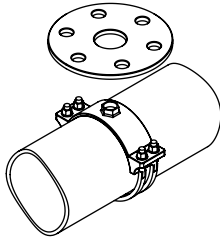

- 3** Install guide plate.

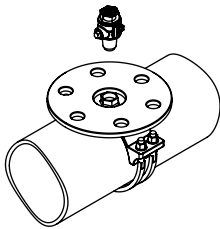

- 4** Thread corporation valve into service saddle. Valve should be open.



- 5** Perform drilling operation.

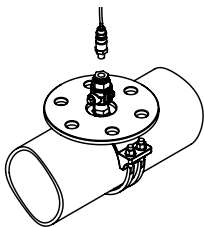

- 6** Apply joint-sealant, dry the connection inlet before inserting the pressure sensor; and then thread pressure sensor into corporation valve. **Open Valve**

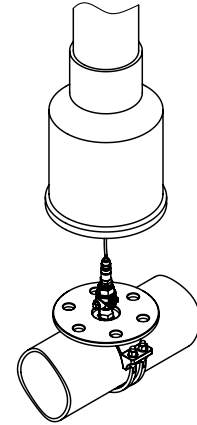

- 7** Install valve box over the assembly.

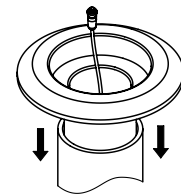

- 8** Carefully back fill and pave area around valve box per direction by engineer of record. Be sure to keep the sensor connector within reach.

⚠ DO NOT PAVE OVER RTU!
(Use valve box lid or cast iron blank) **⚠**

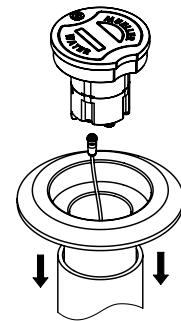

- 9** Plug sensor cable into RTU and rotate nut 1/4 turn counterclockwise. Insert RTU into adjustable top. Be certain lid of RTU is flush with valve box frame.

- 10** Record Location (see reverse side)

Important: Please complete form on reverse and return to administrator after installation

Bracket Installation Instructions



1 Verify Cell Coverage at Installation Site.

Place cell phone of same carrier (Verizon or AT&T) at the planned installation location, and verify the signal quality. Indicator must have a minimum of two (2) bars.

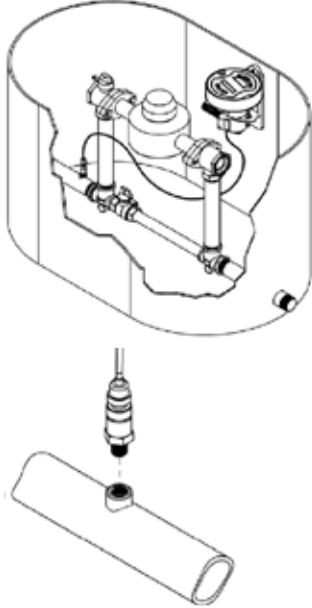

2 Apply joint-sealant and thread pressure sensor into 1/4" NPT port. Turn on the water.

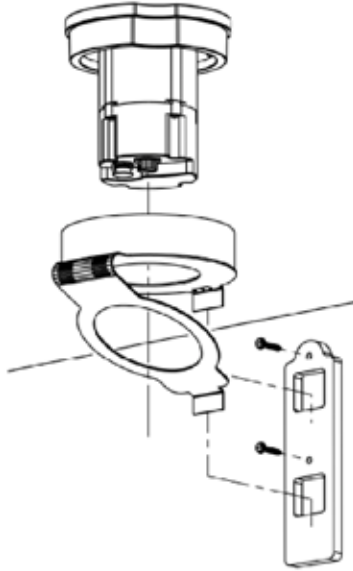

3 Install mounting bracket to wall of meter box/vault.

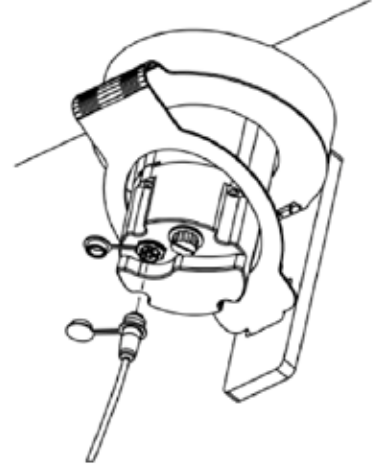

4 Plug sensor cable into RTU and rotate nut 1/4 turn counterclockwise.

Sticker with
serial number
goes here

IMPORTANT: Please record location of installation and return this document to administrator named on the shipping label of this package.

Address: _____

GPS location (if available)

Latitude: _____ Longitude: _____

Installed by: _____ Date: _____



Mueller Co. LLC
1200 Abernathy Rd., Suite 1200
Atlanta, GA 30328
www.muellercompany.com
moreinfo@muellercompany.com

Phone: 1.423.209.4800
Toll Free: 1.800.423.1323
Canada: 1.705.719.9965

Copyright © 2017 Mueller Co., LLC. All Rights Reserved.

The trademarks, logos and service marks displayed in this document herein are the property of Mueller Co., LLC, its affiliates or other third parties. Products above marked with a section symbol (§) are subject to patents or patent applications. For details, visit www.mwppat.com. These products are intended for use in potable water applications. Please contact your Mueller Sales or Customer Service Representative concerning any other application(s).

Form 12971 - Rev 9/17