

Sentinel® 250 Fire Hydrant

**US
PIPE**
**VALVE &
HYDRANT**

PRODUCT FEATURES

- 3-way hydrant: 250psig/17barg maximum working pressure, 500psig/34barg test pressure.
- UL Listed and FM approved. UL 246 and FM 1510 specifications.
- Meets or exceeds all applicable requirements of ANSI/AWWA C502 Standard.
- O-ring sealed Bonnet and Ground Coupling – better leak resistance, easier maintenance.
- Lubrication port in top of Revolving Nut to allow easy injection of lubricating grease – standard plug can be replaced with zerk fitting for added convenience.
- Positive lubrication of stem threads and bearing surfaces each time hydrant is operated. The revolving nut has 3 channels to distribute lubricating grease to stem threads and both sides of thrust collar each time hydrant is operated to assure easy operation.
- Full flow performance – large radius hose and pumper openings and conical Upper Valve Plate reduce turbulence and provide low friction loss.
- Field replaceable, O-ring sealed Hose and Pumper Nozzles – threaded in place and retained by stainless steel locks – NST or BSP threads.
- O-ring sealed Bronze Seat Ring – resists corrosion and easily removed for maintenance through top of hydrant.
- Traffic Coupling and Stainless Steel Stem Coupling – if hydrant is hit by vehicle, the couplings break preventing damage to stem and main valve, and uncontrolled water flow – couplings will not break into pieces that could drop down and affect valve operation.
- Double Bronze Drains – each time main valve opens or closes, drain valves forceflush drain openings to keep them open for effective barrel drainage.
- Inlet Connections: 6"/DN150 Flanged ANSI B16.1 Class 125 Flat Face (optional PN10, PN16 drilling).
- Available as 2-Hole & 1 Pumper or 2-Hose only.

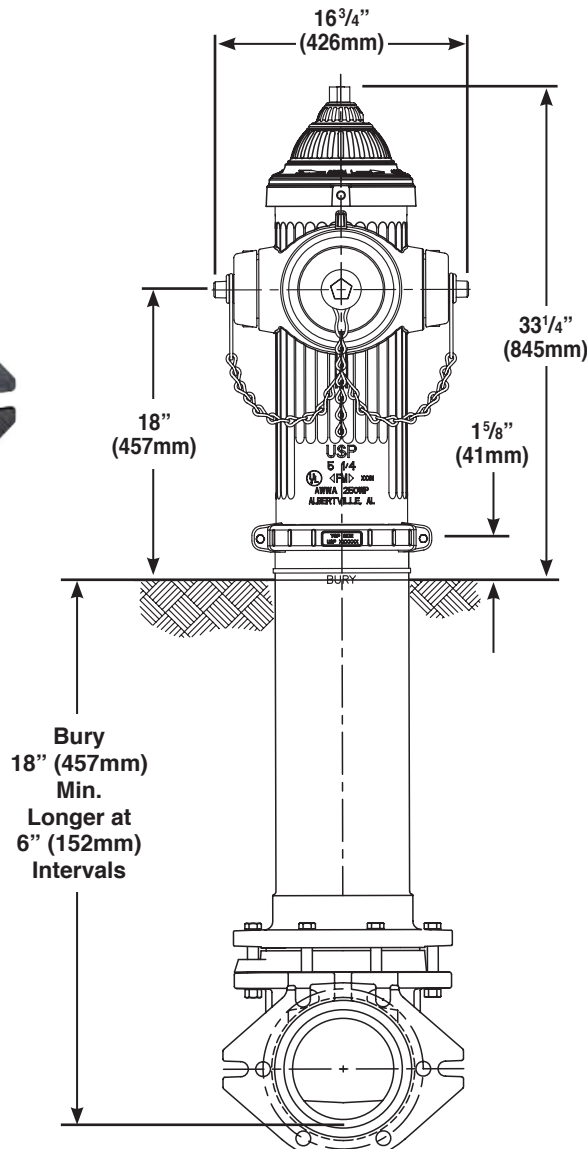

Sentinel® 250 Fire Hydrant



**VALVE &
HYDRANT**

PARTS LIST

ID	PART NAME	MATERIAL
U-1	Operating Nut with Lubrication Port	Ductile Iron
U-2	Operating Nut Seal	Rubber
U-3	Operating Nut Locking Pin	Steel
U-4	Hydrant Lubricant (in chamber)	Diana 2100
U-5	Travel Stop Nut	Steel
U-6	Hold Down Nut	Bronze
U-7	Hold Down Nut Screw	Steel
U-8	Bonnet	Ductile Iron
U-9	Bonnet Locking Screw	Stainless Steel
U-10	Bonnet Seal	Rubber
U-11	Hold Down Nut O-ring	Rubber
U-12	Bonnet - Revolving Nut O-rings	Rubber
U-13	Revolving Nut	Bronze
U-14	Inner Revolving Nut O-rings	Rubber
U-15	Pumper Nozzle	Bronze
U-16	Pumper Nozzle Cap Gasket	Rubber
U-17	Pumper Nozzle Cap	Cast Iron
U-18	Pumper Nozzle O-ring	Rubber
U-19	Nozzle Lock	Stainless Steel
U-20	Hose Nozzle	Bronze
U-21	Hose Nozzle Cap Gasket	Rubber
U-22	Hose Nozzle O-ring	Rubber
U-23	Hose Nozzle Cap	Cast Iron
U-24	Valve Rod Upper	Steel
U-25	Standpipe Upper	Ductile Iron
U-26	Stem Coupling	Stainless Steel
U-27	Cotter Pin	Stainless Steel
U-28	Clevis Pins	Stainless Steel
U-29	Traffic Flange O-ring	Rubber
U-30	Traffic Standpipe Coupling Halve	Cast Iron
U-31	Standpipe Coupling Nuts & Bolts	Stainless Steel
U-32	Valve Rod Lower	Steel
U-33	Standpipe Lower	Cast Iron
U-34	Top Plate Pin - Shear Proof	Stainless Steel
U-35	Upper Valve Plate	Bronze
U-36	Drain Valve Facing	Plastic
U-37	Drain Valve Facing Screw	Stainless Steel
U-38	Bottom Seat O-ring	Rubber
U-39	Drain Ring	Bronze
U-40	Seat Ring	Bronze
U-41	Drain Ring Housing	Cast Iron
U-42	Drain Ring Housing O-ring	Rubber
U-43	Main Valve	Rubber
U-44	Lower Valve Plate	Cast Iron
U-45	Cap Chains	Steel
U-46	Chain Hooks	Steel
U-47	Upper Stem Pin	Stainless Steel
U-48	Shoe Bolt and Nut	Steel*
U-50	Shoe	Ductile Iron
U-52	Top Seat O-ring	Rubber
U-56	Anti-Friction Bearing	Acetal
U-57	Sleeve	Copper
U-58	Stem O-ring	Rubber

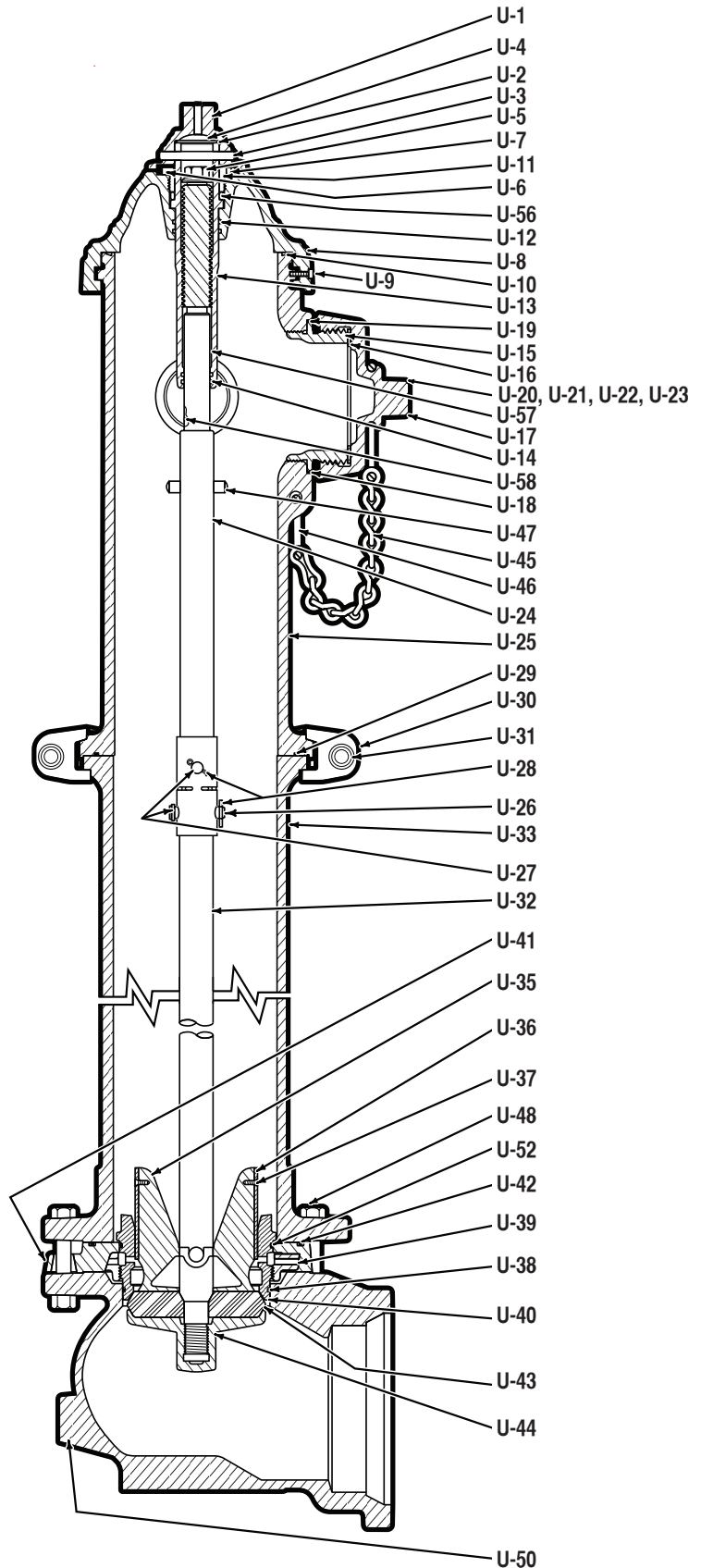

*Stainless steel fasteners available as an option.