

HYDRO-GUARD®

HG-4 Sub-Surface Discharge Unit

⚠ WARNING:

Failure to read and follow the instructions contained within this manual could result in serious personal injury, and/or damage to the Hydro-Guard® Automatic Flushing Device.

1. Each person involved in the assembly, installation and/or maintenance of the Hydro-Guard Automatic Flushing Device must read this manual carefully and follow all instructions prior to performing any installation or maintenance procedures involving the Unit.
2. Verify the drainage path prior to installation to ensure that pedestrian and vehicular hazards will not be created by the installation and use of the Hydro-Guard Automatic Flushing Device (in areas in which freezing may occur, special attention should be given to this procedure).
3. Never assemble, disassemble, or perform Hydro-Guard maintenance unless the influent supply valve has been closed, verified and secured, and internal piping pressure has been relieved.
4. Always use all necessary safety equipment and follow all recommended procedures when installing, operating and maintaining the Hydro-Guard Automatic Flushing Device.
5. Perform annual safety inspections and replace worn or defective parts.
6. Operate the Hydro-Guard Automatic Flushing Device only when fully installed and correctly assembled.

⚠ CAUTION:

The recommended optimal operating pressure for a Hydro-Guard® Automatic Flushing System is between 20psi and 120psi. In the event pressure may exceed 120psi it is recommended that a Pressure Regulating Valve be installed ahead of the Hydro-Guard flushing system.

TABLE OF CONTENTS PAGE

Installation Instructions	2
Programming Unit	3-4
Disassembly and Reassembly Instructions	5
Options and Upgrades	6
Parts	7

Mueller Co.

Reliable Connections™

Customer Service Center
Decatur, Illinois
800.423.1323

www.muellercompany.com/hydro-guard
moreinfo@muellercompany.com

HYDRO-GUARD® HG-4 Sub-Surface Discharge Unit

Installation Instructions

GENERAL

Overview

The Hydro-Guard® HG-4 Sub-Surface Discharge Unit, the industry's premium patented, program-mable flushing apparatus, is suitable for year-round use in cold to extreme cold climates. This Automatic Flushing System has been designed, engineered, and manufactured to provide outstanding dependability and performance.

Please read and retain this manual for future training, reference, troubleshooting, and maintenance.

Site Evaluation

Each Hydro-Guard® System installation is unique and will require a minimum of advance planning. Prior to the installation of the device, the drainage patterns for the intended installation location should be reviewed. The drainage pattern must permit discharged water to flow away from the Hydro-Guard® Unit. Discharged water flushed from the Hydro-Guard® Unit must be routed away from the device. It is recommended that a 6" catch pipe (by others) be installed inside

of the HG-4's external cabinet. The catch pipe shall be mounted at least 3" under the discharge piping of the HG-4 (see Typical Installation illustration). The 6" pipe shall be installed a minimum of 24" below grade before a 90-degree bend or pipe size reduction. If desired, the 6" pipe can be reduced to a 3" or 4" pipe to continue the routing of the flow to a final discharge point. The recommended final discharge points may include a storm drain, drainage or retention pond, or a storm swale.

INSTALLATION

Hydro-Guard® HG-4 Unit

1. Remove the Hydro-Guard® Unit from its packaging and inspect for possible damage during shipping.
2. Excavate a suitably-sized ditch ensuring it is connected on one side to the utility's service line trench. Remove any debris that might create uneven pressure on the Unit. Compact the bottom of the hole in order to minimize settling after installation. Place #57 stone, then non-compacted clean bedding material within the bottom of the hole. Turn off service line feed.
3. Slowly lower the Hydro-Guard® Unit into place, pressing it firmly into the noncompacted bedding material until it is fully seated. Ensure that the Unit is level before beginning the backfilling operation (the bottom of the ground plate should be approximately 1" above the final grade).
4. Connect the utility's water system to the Hydro-Guard® Unit by means of the 2" threaded connection.
5. Backfill the hole around and under the Unit's below grade base with clean fill and/or #57 stone. Backfilling should be accomplished in 6" compacted lifts. Check that the Unit is level.

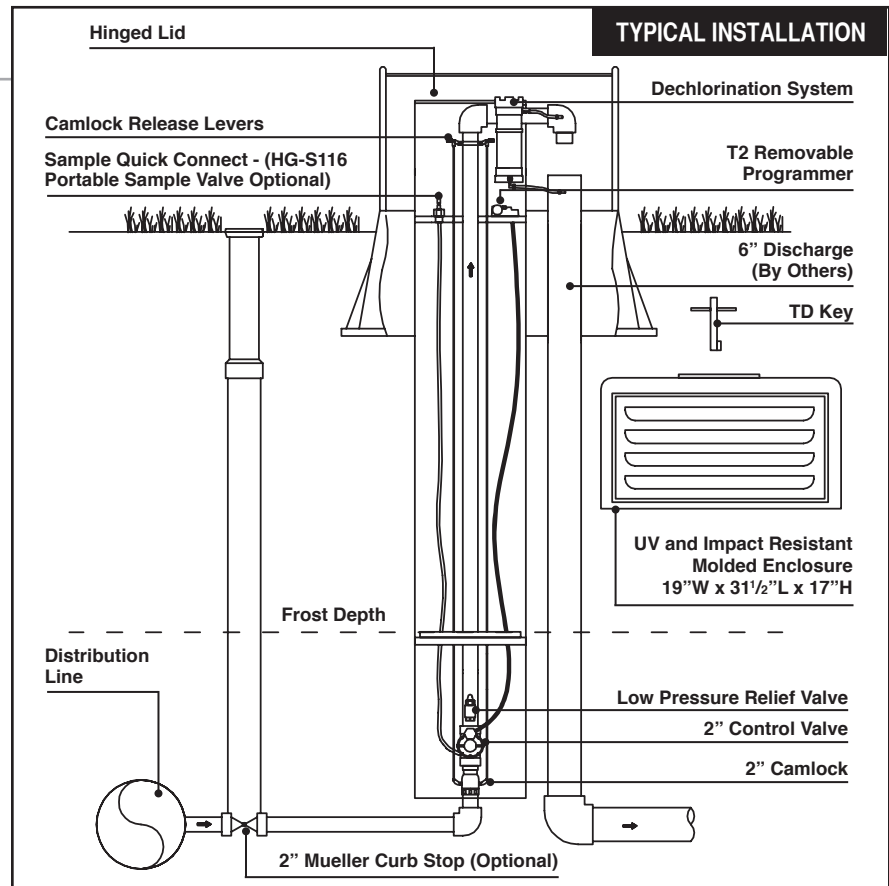

6. After installation is complete, sod the area around the Hydro-Guard® Unit or take other steps in order to prevent erosion. Inspect the area immediately around the Unit in order to ensure that the existing ground cover is not subject to severe erosion. You may opt to create a custom installation to best suit your needs.

7. Disinfect the Hydro-Guard® Flushing Device in accordance with the utility's policy. DO NOT exceed the dosage and contact times recommended by the AWWA.
8. The Hydro-Guard® Automatic Flushing Device may now be programmed and placed into service.

HYDRO-GUARD® HG-4 Sub-Surface Discharge Unit

Programming Unit

PROGRAMMING HYDRO-GUARD® UNIT FOR OPERATION

HG-4 (Requires Handheld) TBOS-II Programming Instructions

The TBOS-II handheld uses on screen prompts for intuitive programming. It will control current programming interface (T-2: dark gray case), as well as the previous model of programming interface (T-1 modules programmed by the TBOS-US handheld).

Features

- 1 to 24 possible flushing events daily, or on selected days weekly, 365-day calendar
- Flush duration 1 minute to 12 hours (1 minute increments)
- Preprogram and store up to 3 different schedules
- Rechargeable battery (low battery indicator shows both handheld and controller battery conditions) with recharging adaptor (9V lithium battery can be used in the built-in programming interface)

NOTE: *In that the handheld was designed by its manufacturer to program irrigation systems, many displays use irrigation terminology. In the following instructions, in such cases the equivalent flushing terminology is shown in parentheses.*

⚠ CAUTION: Leaving the infrared connector connected to the built-in programming interface can significantly reduce the battery life of the 9-volt batteries in the programming interface and the rechargeable battery in the TBOS-II handheld.

TBOS-II Handheld Keys

HOME – press three seconds to turn handheld on.

ABC – press to choose from three available programs (to store a program when preprogramming, or uploading a program to controller).

LEFT and **RIGHT ARROWS** – move cursor left or right, also go back or forward one screen.

ON and **OFF/+** and **- /UP** and **DOWN ARROWS** – Used to set flushing events on or off, move selector up and down on screen, or increase or decrease duration and other values.

OK – press to make selection final.

TBOS-II Handheld Home Screen Menu

1. **TBOS infra-red** – accessible only when connected to programming interface via the IR cable: select to connect handheld to programming interface via infrared cable and access programs on it, or to transfer programs from handheld to programming interface.
2. **Templates (TBOS-II)** – select to program handheld without connecting to programming interface.
3. **Settings** – select to access and set time, date, and various other available user settings.

First Time Use

1. Press **HOME** key for three seconds to turn on handheld.
2. Press **RIGHT ARROW** key or the **OK** key to access “Settings”.
3. Use **DOWN ARROW** to select and set the following:
 - a) Date and Time
 - b) Contrast of the screen
 - c) Name of the handheld controller (can be assigned to a specific operator)
 - d) Language (English, French, Spanish, Italian, Dutch, Portuguese, Turkish, etc.)

NOTE: *Programming instructions for all available languages are available by contacting Mueller Co. at 800-423-1323.*

Programming Flushing Schedule

There are two ways to proceed:

- Select “**TBOS-II infra-red**” if IR cable is connected to a TBOS-II programming interface to access, change or load programs there, or
- Select “**Templates (TBOS-II)**” to create or change programs stored on the handheld to load onto a programming interface at a later time (IR cable not used).

NOTE: *The home screen for “TBOS-II infra-red” shows battery condition for programming interface and ON/OFF state of any current operation in progress.*

1. Press **HOME** key for three seconds to turn handheld on.
2. Press **RIGHT ARROW** key or the **OK** key to access “Settings”.
3. Use **DOWN ARROW** to select “Templates” and press **OK**.
4. Use **DOWN ARROW** to select “Programs” and press **OK**.
5. Use **DOWN ARROW** to select “Watering Days” (Days to Flush) and press **OK**.
6. Use **UP/DOWN ARROWS** to select one of the following:
 - a) **Custom Cycle (Week):** use **RIGHT/LEFT ARROWS** to move to days of the week, use **ON/OFF** keys to highlight days on which to flush, then press **OK** to confirm days when selections are complete.
 - b) **Even Days:** to Flush on even dates, press **OK** to set.
 - c) **Odd Days:** to Flush on odd dates including 31st, press **OK** to set.
 - d) **Odd Days 31:** to Flush on odd dated except 31st, press **OK** to set.
 - e) **Cyclical:** to Flush every “X” days, set “X” using **ON/OFF** keys (X=1 to 31), press **OK** to set; then set start date “dd/mm/yyyy” using **ON/OFF** keys, press **OK** to set.

HYDRO-GUARD® HG-4 Sub-Surface Discharge Unit

Programming Unit

7. Use **LEFT ARROW** to navigate back to the program “**Settings**” menu.
 8. Select “**Start times**”, press **OK** to set.
 9. Use **ABC** to select program to be set up.
 - a) Set hours and minutes for each start time (up to 8 per program) using **ON/OFF** keys, press **OK** to set each (hours are indicated using 24 hour clock). [When exiting this screen, start times will automatically sort into chronological order.]
 10. Use **LEFT ARROW** to navigate back to the program “**Settings**” menu.
 - a) Use **DOWN ARROW** to select “**Valve Run Times**” (Flush Duration), press **OK** to set.
2. Once data receipt is complete press **RIGHT ARROW** to move to “**Settings**” menu.
 3. From “**TBOS-II infra-red**” settings screen select “**Transmit**” and press **OK** again. When program to be transmitted appears, press **OK** to confirm.
 4. To clear programs A, B, or C: from “**TBOS-II infra-red**” welcome screen, use **DOWN ARROW** to select “**Clear Programs**” and press **OK**, then select type of program to clear and follow prompts.
 5. To check programs A, B, or C: from “**TBOS-II infra-red**” welcome screen, use **DOWN ARROW** to select “**Programs**” and press **OK**, then select what is to be checked and follow prompts.

NOTE: Although six valves may be shown on screen, only Valve 1 is used to manage the Hydro-Guard® unit.

- b) Use **ON/OFF** keys to select program A, B and/or C (one or more can be assigned).
- c) Then use **ON/OFF** keys to set Flush duration (hours and/or minutes) for program just set, use **LEFT/RIGHT ARROW** keys to move between hours and minutes and **+** and **-** keys to set times (1 minute to 12 hours), press **OK** to set.

Transmitting Time, Date and Programs to Programming Interface, Clearing/Checking Programs, Manual Start

Connect handheld to programming interface using IR cable.

1. To transmit: from home screen, use **DOWN ARROW** to select “**TBOS-II infrared**” and press **OK**. TBOS-II handheld will receive data (settings) from built-in programming interface.

Manual Flushing

Using TBOS-II handheld on the T-2 built-in programming interface (dark gray in color).

NOTE: Manual start cannot be initiated if there is no program in the programming interface.

1. To start manual flushing from “**TBOS-II infra-red**” welcome screen.
 - a) Use **DOWN ARROW** to select “**Manual Watering**” (Manual Flush) and press **OK**,
 - b) Select “**Start Valve**” (Open Control Valve) then using **ON/OFF** keys select “**Valve 1**” and press **OK**,
 - c) Use **ON/OFF** keys to set the manual Flush Time (1 minute to 12 hours) and press **OK** to confirm. Flushing will start after a four (4) second delay.

Stop Manual Flush Sequence

1. Reconnect IR cable to built-in interface, then hold down **HOME** key on handheld.
2. Use **RIGHT ARROW** to select “**TBOS-II infra-red**” menu and select “**Manual Watering**.”
3. Select “**Cancel Irrigation**” to cease the manual flush sequence.

Communication Failure:

Possible Causes /Solutions

1. The programming pod’s battery is low or out of power or the Handheld Programmer is low or out of power; replace battery.
2. There might be a problem with a connection or solenoid. Perform an electrical system check.

NOTES: The Pod’s internal memory lasts only 3 minutes. Any time the battery within the Programming Pod dies, it is necessary to plug the Handheld Programmer directly into the Pod and re-assign the Actuator ID and reprogram the Unit. While repeating the programming steps is only a minor inconvenience, a proactive approach to battery maintenance will serve to alleviate the frequency with which these steps must be completed.

For all other programming questions, please refer to the Hydro-Guard® Programming Guide. If the information you require is not available therein, please contact Hydro-Guard® Customer Service at 877.864.8500.

HYDRO-GUARD® HG-4 Sub-Surface Discharge Unit

Disassembly and Reassembly Instructions

HG-4 DISASSEMBLY AND REASSEMBLY INSTRUCTIONS

 **TOOLS NEEDED:** HG-A2023 Security Tool, Philips screwdriver, flat-head screwdriver

Although the Hydro-Guard® Sub-Surface Unit was delivered completely assembled, it may be necessary and/or desirable to disassemble portions of the Unit, or the Unit in its entirety, in order to allow for required service and maintenance. If disassembly is necessary, please follow the directions below. Always close the curb stop before working on the unit.

HG-4 Battery Replacement

1. Remove protective external cover and unlatch the cover of the internal protective sleeve.
2. Unscrew the grey cap off the watertight housing of the integrated T-2 programming interface. Pull the battery box out of the watertight housing. Replace 9-volt battery with a 9-volt lithium battery.
3. Place the battery back into the watertight integrated T-2 programming interface making certain to tighten the screw-on lid until snug.
4. Relatch the cover of the internal in-ground, protective sleeve and return the external housing to its proper location.

Disassembly

1. Shut off water supply to unit and remove the green housing cover.
2. Unlatch hasp on hinged cover of HG-4 protective ground sleeve.
3. Push both handles down to release banjo coupling from the bottom plate.
4. Pull straight up to remove the internal assembly.

Electrical System Check

1. Disassemble unit.
2. Unscrew Solenoid and be careful NOT TO LOSE THE O-RING.
3. Using the TBOS-II handheld, connect the infrared connector of the handheld to the antenna on the controller interface mounted inside of the device.
4. Using the programming keys of the handheld, run a 2 minute manual flush sequence.

NOTE: Plunger inside solenoid should be down when running and up when off.

5. To prevent the loss of the solenoid plunger and spring, place an object or have a finger over the plunger of the solenoid. Allow the plunger enough space to kick out of the solenoid body into the object or finger hovering over it.
6. If test is successful re-assemble unit.

If everything checks out, the electrical system is in working order.

Valve Disassembly and Check

1. Remove six (6) bolts from top cover.
2. Slowly pull cover off the valve.
3. Remove rubber diaphragm and inspect for holes or worn areas.
4. Be certain to avoid contacting the EPDM rubber diaphragm with pipe putty. Pipe putty can cause the rubber to thin out and leak.
5. Remove the valve screen plug on the lower half of the valve body. Be careful not to exert too much force when pulling plug out.

6. Check for debris in the valve screen on the inlet side with the lower half of the valve body by removing the valve screen plug.
7. Return valve plug to its proper location when debris screen is cleared.
8. Replace the top cover back onto the diaphragm – make sure to line up the openings in both.
9. Match up the top cover of the valve with the bottom portion. The arrows have to align on both portions.
10. Replace the bolts and tighten down.

Reassembly

1. Install internal assembly into body, handles facing down. Set unit straight down until it rests on the male banjo coupling. Pull handles up to lock into place.
2. Return hinged cover to its correct position and relatch the hasp lock. Secure with a padlock if so desired.
3. Turn on the water supply to the unit. Using the TBOS-II handheld, run a 2 minute manual flush.
4. Install the housing cover over the unit and lock in place.

HYDRO-GUARD® HG-4 Sub-Surface Discharge Unit

Options and Upgrades

HYDRO-GUARD® FEATURES, OPTIONS AND UPGRADES

The following is a brief overview and introduction to Hydro-Guard® Sampling, Options and Upgrades.

Integrated Sample Station

A standard feature on the HG-4 Sub-Surface Discharge Unit, Hydro-Guard's Sample Port allows the end user to collect the sample. You may wish to run a brief manual-mode flush prior to the collection in order to ensure water indicative of the main-line water quality is being sampled. Generally a two-minute flush is sufficient. Track your residual levels and alter flushing frequency and/or duration in order to maximize water conservation.

Dechlorination

All Hydro-Guard® Units include dechlorination systems. Dechlorination takes place as a portion of the discharged water passes through a housing containing either sodium sulfite or ascorbic acid tablets. This action creates a concentrated dechlorination solution that then mixes with the non-directly treated portion of the discharge to effectively dechlorinate the entire discharge volume. This option is available to be retrofitted onto the HG-4 Sub-Surface Discharge Unit.

S.M.A.R.T. Upgrade

Call 877.864.8500 and ask about upgrading your unit to a Hydro-Guard® S.M.A.R.T. flushing system that:

- Monitors chlorine levels (total or free).
- Flushes distribution line when residual disinfectant drops below acceptable levels.
- Monitoring of pH, flow, temperature or turbidity available.
- Two way real-time communication via cellular, wifi, ethernet or BlueTooth®.

HYDRO-GUARD® HG-4 Sub-Surface Discharge Unit

Parts

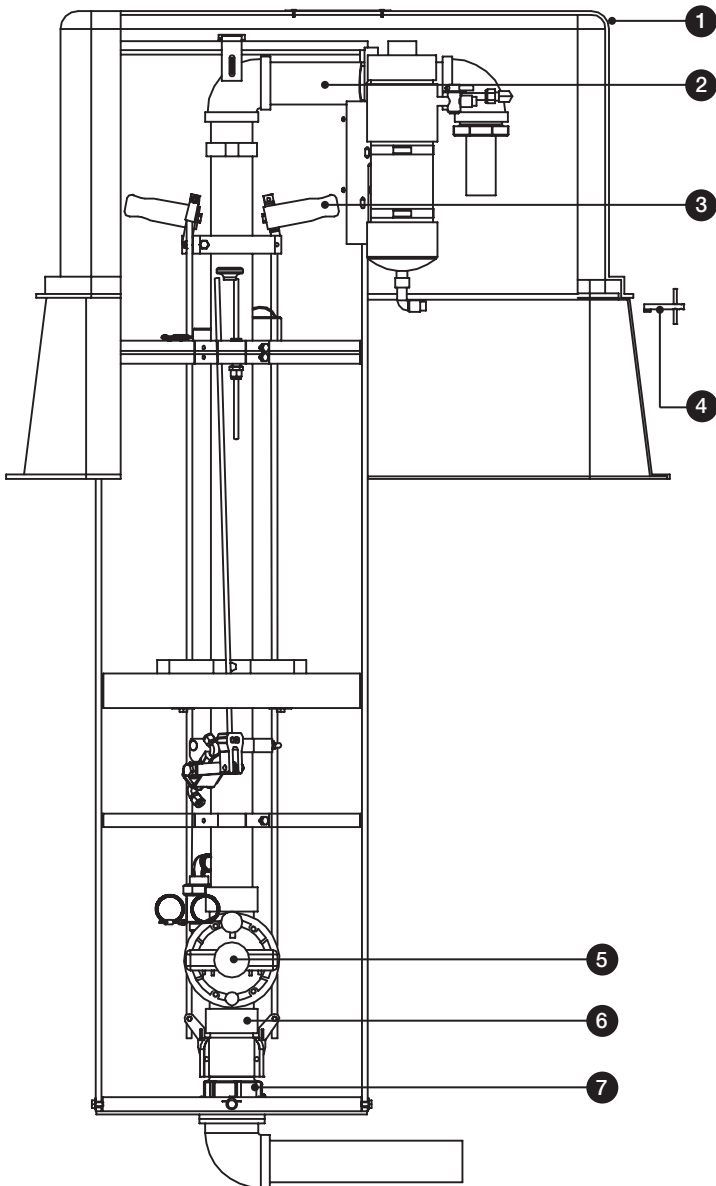

ID	PART #	DESCRIPTION
1	HG-2201	UV Protective Housing
2	546553	Dechlorination Sub Assembly
3	HG-S124	Latching Sub Assembly
4	HG-A2006	TD Key
5	HG-123100	Low-Pressure Relief Valve
6	HG-S125	2" Camlock
7	HG-S106	Bottom Plate Sub Assembly
8	545687	Removable Programmable Controller

REPLACEMENT PARTS

HG-S106	HG-4 Bottom Plate Sub Assembly
HG-S124	Latching Sub Assembly
545729	Centering Star
HG-02125	1/4" x 1/4" Hex Bolt
HG-S295	TBOS2 Controller Assembly
HG-13176	1/4" x 3/4" Phil Pan Screw
HG-S128	Relief Valve Sub Assembly
HG-S126	Insulation Star Sub Assembly
546549	HG-4 Top Plate Sub Assembly
HG-2201	DIV 1021-R
HG-21088	HG-4 Name Plate
HG-V129	Silver Thermal Insulation
HG-A2006	TD Key
546372	HG-4 Sample Port
HG-V116	Bulkhead Union Brass
HG-13198	1/4 - 20 Threaded Knob
HG-V105	1/4 Polyurethane tube
HG-123108	1/4" x 1/4" NPT Adaptor
546531	HG4 Sample Rod
HG-V105	1/4 Polyurethane tube
HG-S325	HG-4 Valve Sub Assembly
546550	HG-4 Outlet Sub Assembly
HG-S117	HG-4 Bottom Plate Connection
546522	HG-4 Below-Grade Housing
546526	HG-4 Latching Rod
HG-S318	HG-4 Latching Solenoid
546535	HG-4 Main Nipple
546553	HG-4 Dechlor Sub Assembly

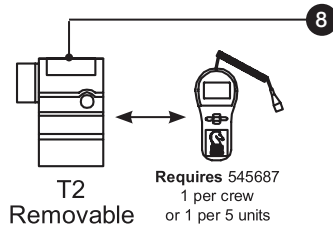



Reliable Connections[®]

Water (U.S.)
1.800.423.1323
www.muellercompany.com
moreinfo@muellercompany.com

International
1.423.490.9555
www.mueller-international.com
international@muellercompany.com

Copyright © 2017 Mueller Co., LLC. All Rights Reserved.

The trademarks, logos and service marks displayed in this document herein are the property of Mueller Co., LLC, its affiliates or other third parties.

Products marked with a section symbol (§) are subject to patents or patent applications. For details, visit www.mwppat.com. These products are intended for use in potable water applications. Please contact your Mueller Sales or Customer Service Representative concerning any other application(s).

Form 12775 - Rev 07/17