



# Canada Valve Fire Hydrants

Century & B-50-B Models



**Mueller Canada**

Reliable Connections<sup>®</sup>

# Canada Valve Fire Hydrants

Designed and manufactured to assure years of uninterrupted service with the E/M Operating System.

## Century B-50-B18 / B-50-B24 / B-50-B Monitor

### 1 Acetal Thrust Bearing

Corrosion-proof acetal thrust bearing minimizes torque required to open hydrant.

### 2 Permanently Lubricated

Operating threads are permanently lubricated in a grease-filled polymer reservoir.

### 3 O-ring

O-ring seals provide “dry-top” hydrant and prevents leakage into hydrant barrel.

### 4 Superior Design

Large radius on entrance of nozzles minimizes friction loss

### 5 Sealed Nozzles

Resilient sealed nozzles resist handling damage and are quickly and easily replaced.

### 6 Traffic Feature

The Traffic feature minimizes repair costs due to traffic impact.

### 7 Two-Piece Barrel Flange

Two-piece barrel flange design permits positioning upper barrel to obtain any nozzle orientation.

### 8 Stainless Steel Hardware

Stainless steel nuts and bolts at base flange provide superior corrosion protection.

### 9 Ductile Iron Components

Ductile iron lower barrel, ductile base flange, and ductile floating flange eliminate damage below ground level

### 10 Self-Flushing Drain

Multi-port, self-flushing drain assures proper draining of hydrant barrel.

### 11 “Venturi”-Type Flow Passage

Venturi-type flow passage maximizes flow.

### 12 Compression-Type Valve Seats

Compression-type valve seats with pressure for positive seal in event of traffic damage.

### 13 Spherical Base

Large ductile spherical base for minimum obstruction to flow and no pockets to collect sediment. NSF 61 approved epoxy coating used.

### 14 Stem Seal

O-ring stem seal prevents leakage into hydrant barrel.

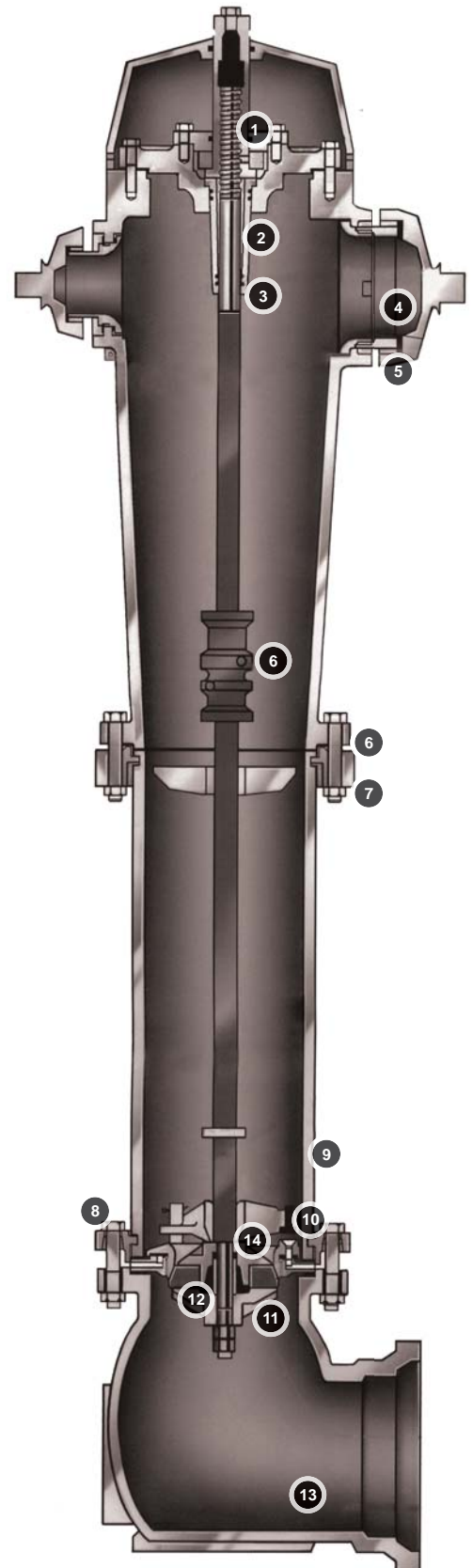



## Century & B-50-B Model Hydrant Features

### E/M (Easy Maintenance) Hydrant Operating System

The Canada Valve Century, B-50-B18, B-50-B24, and Monitor hydrants all feature Mueller Canada's "E/M" Operating System. Designed to minimize the amount of maintenance required to keep the hydrant operating optimally, the "E/M" System utilizes less lubricant and contains fewer moving parts. This results in a hydrant that will provide years of trouble-free service under all kinds of condition and extreme climates. The acetal bearing provides a slick, corrosion-proof bearing surface for the operating nut, allowing the hydrant to be operated with ease. The operating threads and O-rings of the upper rod are enclosed in a corrosion-proof polymer cone that protects and lubricates machined surfaces, additionally reducing friction for the operating nut. The "E/M" Operating System is interchangeable with any Canada Valve hydrant currently in service.

### Interchangeability of Parts

All Century and B-50-B style hydrants use the same basic internal parts. Precision CNC-machined parts ensure fit and interchangeability are never an issue.

### Nozzles

A variety of hose and pumper nozzles are now available on the Canada Valve model hydrants. All nozzles are precision machined to provide consistent, high-quality nozzles. The barrel break flange design allows for infinite adjustment of nozzle orientation with respect to the hydrant inlet.

### Positive Automatic Drain

When the hydrant valve is closed, the drain lever is held away from the drain ports for positive drainage through the drain ring. The drains remain open for the first several turns when the hydrant is opened to allow the drains to be flushed under pressure, removing any foreign matter or sediment.

### Extending Hydrants

Hydrants can be easily extended at the ground line using a standard extension kit available from stock. Canada Valve model hydrants can also be extended at the base, allowing standard lower rod lengths to be maintained.

### Easy Access for Inspection and Maintenance

Removal and inspection of internal parts (rod, valve ball, seat, drain lever, and bearing components) can be accomplished by one person quickly and easily, through the top of the hydrant barrel. Bronze-to-bronze, precision-machined main valve seat threading assures easy removal, even after long periods without servicing.

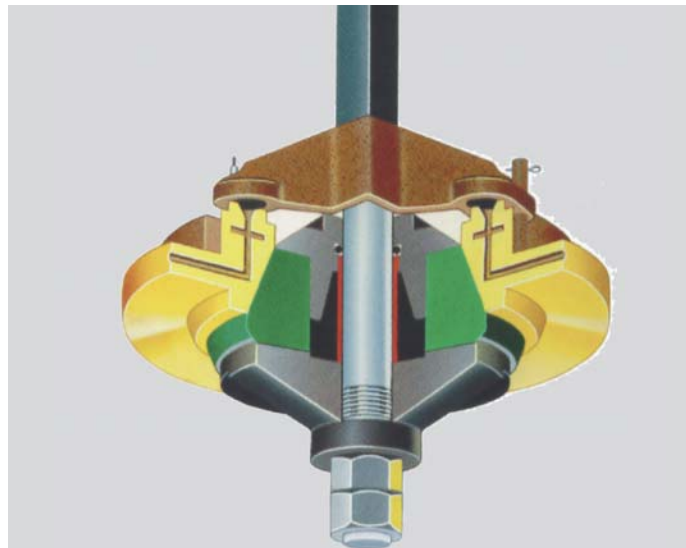



## Mueller Canada offers hydrant options to meet your specifications

### Salt Water Service Hydrants

Hydrants can be supplied with stainless steel and special alloy bronze components, for extreme corrosive conditions.

### Non-Draining Hydrants

Mueller Canada offers hydrants without drain ports where water table conditions do not allow proper drainage, preventing entry of ground water into the hydrant barrel. Standard hydrants can be easily converted to non-drainage after installation. Hydrant barrel should be pumped out after each use.

### Outlet Configurations

Standard hydrant configurations can be modified to meet special application requirements, such as outlets ranging from 2-1/2"-4-1/2" (60mm-110mm).

### Storz Outlets

Storz outlets are manufactured from a bronze alloy and utilize a metal seating face for lasting performance and corrosion resistance.

### Monitor Hydrants

Hydrants are available with a flanged outlet elbow on the upper barrel to facilitate mounting a monitor nozzle (B-50-BM). Flange is 3" ANSI/ASME B16.1 Class 125 (75mm-60kg).



## Delivery and Service

The capacity to deliver the widest array of products and stand behind those products to ensure your satisfaction is our strength. The success of Mueller Canada is dependent upon the success of those who are involved, both inside and outside our company. Therefore, we feel our future is wholly dependent on long-term relationships with our employees, customers and suppliers. This is why we strive to be proactive and responsive to their needs, always looking for a "better way". It's an approach that has set Mueller Canada and its affiliates apart since 1857 and will assure our mutual achievement and prosperity in the future.

Mueller Canada's distributors inventory extensive stocks, helping to assure ready availability. Our sales representatives, strategically located around Canada, are always ready to provide application and installation assistance and help with any special issues.

*For more information about Mueller Canada or to view our full line of water products, please visit [www.muellercanada.com](http://www.muellercanada.com) or call Mueller Canada Customer Service at 1.705.719.9965.*

### Follow Us:



**Mueller Canada**  
82 Hooper Rd.  
Barrie, ON L4N 8Z9

[www.muellercanada.com](http://www.muellercanada.com)  
[more-info@muellercanada.com](mailto:more-info@muellercanada.com)  
Phone: 1.705.719.9965

